

ABBREVIATIONS:
 P.O.B. - POINT OF BEGINNING
 ORB - OFFICIAL RECORD BOOK
 D.B. - DEED BOOK
 P.B. - PLAT BOOK
 NO. - NUMBER
 PG. - PAGE
 R/W - RIGHT-OF-WAY
 SEC. - SECTION
 PBC - PALM BEACH COUNTY
 C. - CENTERLINE
 PBCUE - PALM BEACH COUNTY UTILITY EASEMENT

NAD - NORTH AMERICAN DATUM
 LB - LICENSED BUSINESS
 (D) - DEED DIMENSION
 (C) - CALCULATED DIMENSION
 (G) - GROUND DIMENSION
 12/44/42 - SECTION 12, TOWNSHIP 44 SOUTH, RANGE 42 EAST
 U.E. - UTILITY EASEMENT
 C.M. - 4"x4" CONCRETE MONUMENT WITH NO IDENTIFICATION STAMP

ATLANTIC CHRISTIAN ACADEMY

BEING A REPLAT OF A PORTION OF LOT 6, BLOCK 2, PALM BEACH PLANTATIONS, MODEL LAND COMPANY'S SUBDIVISION OF SECTION 12, TOWNSHIP 44 SOUTH, RANGE 42 EAST, AS RECORDED IN PLAT BOOK 10, PAGE 20, OF THE PUBLIC RECORDS OF PALM BEACH COUNTY, FLORIDA LYING IN SECTION 12, TOWNSHIP 44 SOUTH, RANGE 42 EAST, PALM BEACH COUNTY, FLORIDA

BROWN & PHILLIPS, INC.
 PREPARING SURVEYOR & MAPPER'S STATEMENT
 THIS INSTRUMENT WAS PREPARED BY JOHN E. PHILLIPS III, P.S.M. 4826
 CERTIFICATE OF AUTHORIZATION # LB 6473
 1860 OLD OKEECHOBEE RD., SUITE 509
 WEST PALM BEACH, FLORIDA 33409
 561-615-3988, 615-3986 FAX

169

SHEET 2 OF 2

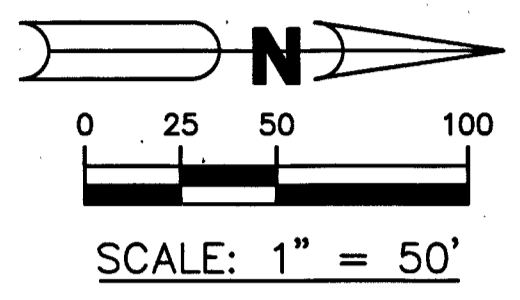

STATE PLANE COORDINATES:
 A. COORDINATES SHOWN ARE GRID
 B. DATUM - NAD 83, 1990 ADJUSTMENT
 C. ZONE - FLORIDA EAST
 D. LINEAR UNIT - US SURVEY FOOT
 E. COORDINATE SYSTEM 1983/1990 STATE PLANE
 F. TRANSVERSE MERCATOR PROJECTION
 G. ALL DISTANCES ARE GROUND, UNLESS NOTED OTHERWISE
 H. SCALE FACTOR = 1.0000359
 I. GROUND DISTANCE X SCALE FACTOR=GRID DISTANCE
 J. ROTATION EQUATION: NONE

SYMBOLS:
 □ PERMANENT REFERENCE MONUMENT (P.R.M.), SET 4"x4" CONCRETE MONUMENT WITH DISK STAMPED "LB6473", UNLESS NOTED OTHERWISE

